

POSTGRESQL PERFORMANCE TUNING

BRUCE MOMJIAN,
ENTERPRISEDB

SEPTEMBER, 2007

*Enterprise***DB**TM

ABSTRACT

POSTGRESQL is an open-source, full-featured relational database. This presentation gives an overview of performance tuning with POSTGRESQL.

PERFORMANCE

- CACHING
- INTERNALS
- STORAGE

CACHING



CACHES

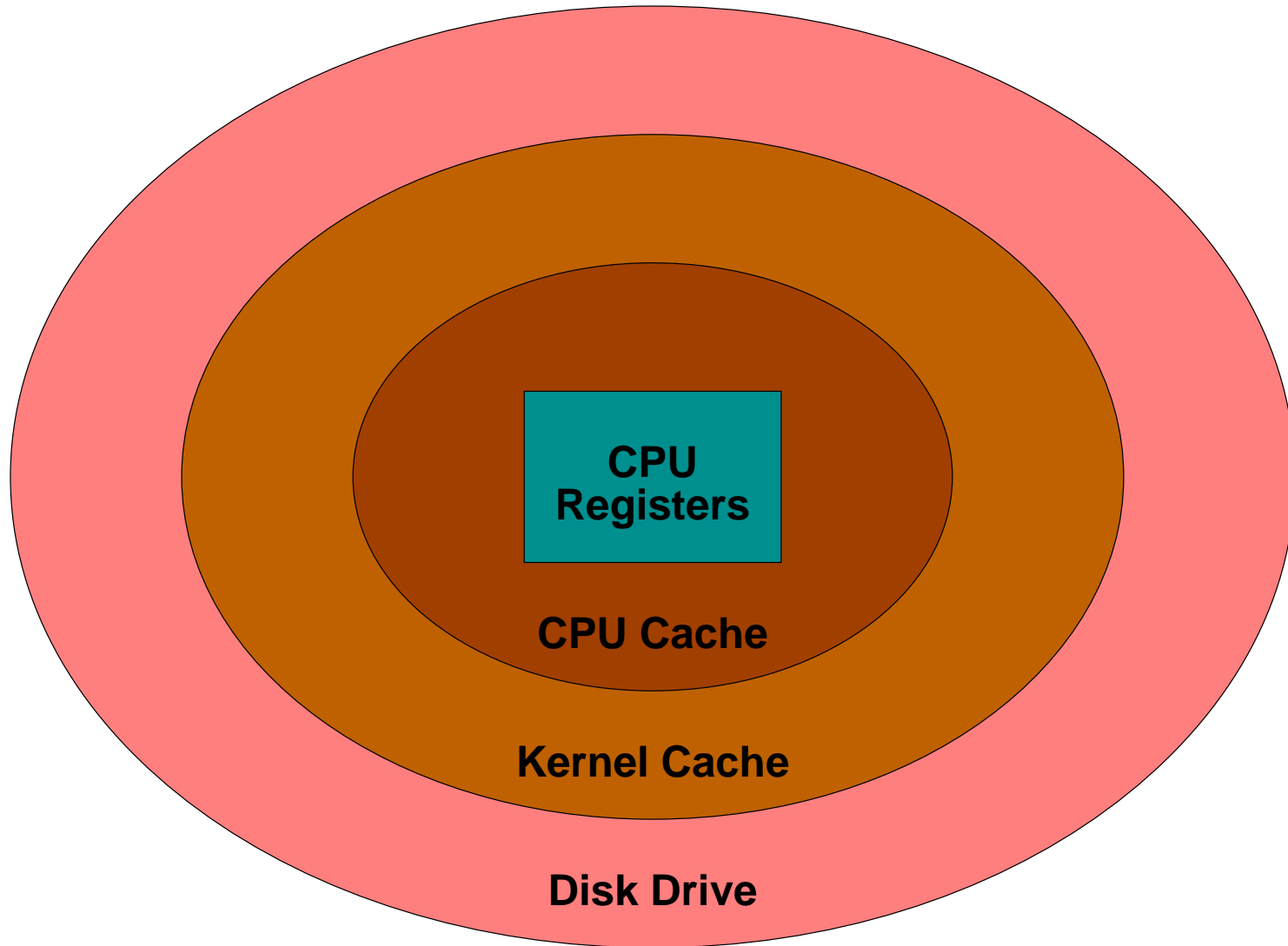

CACHE SIZES

STORAGE AREA	MEASURED IN
CPU REGISTERS	BYTES
CPU CACHE	KILOBYTES
RAM	MEGABYTES
DISK DRIVES	GIGABYTES

BUFFER / DISK INTERACTION

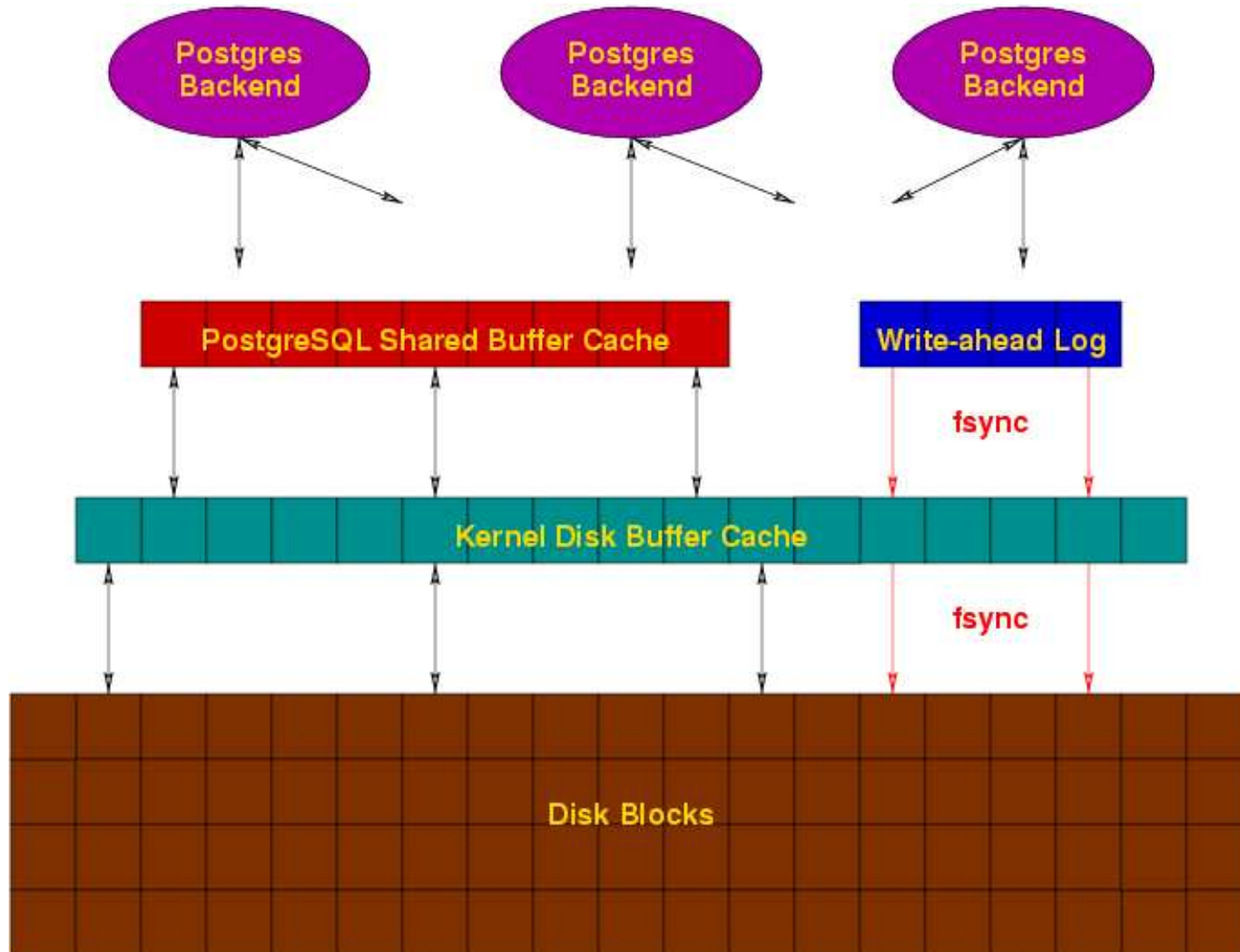

MEMORY USAGE

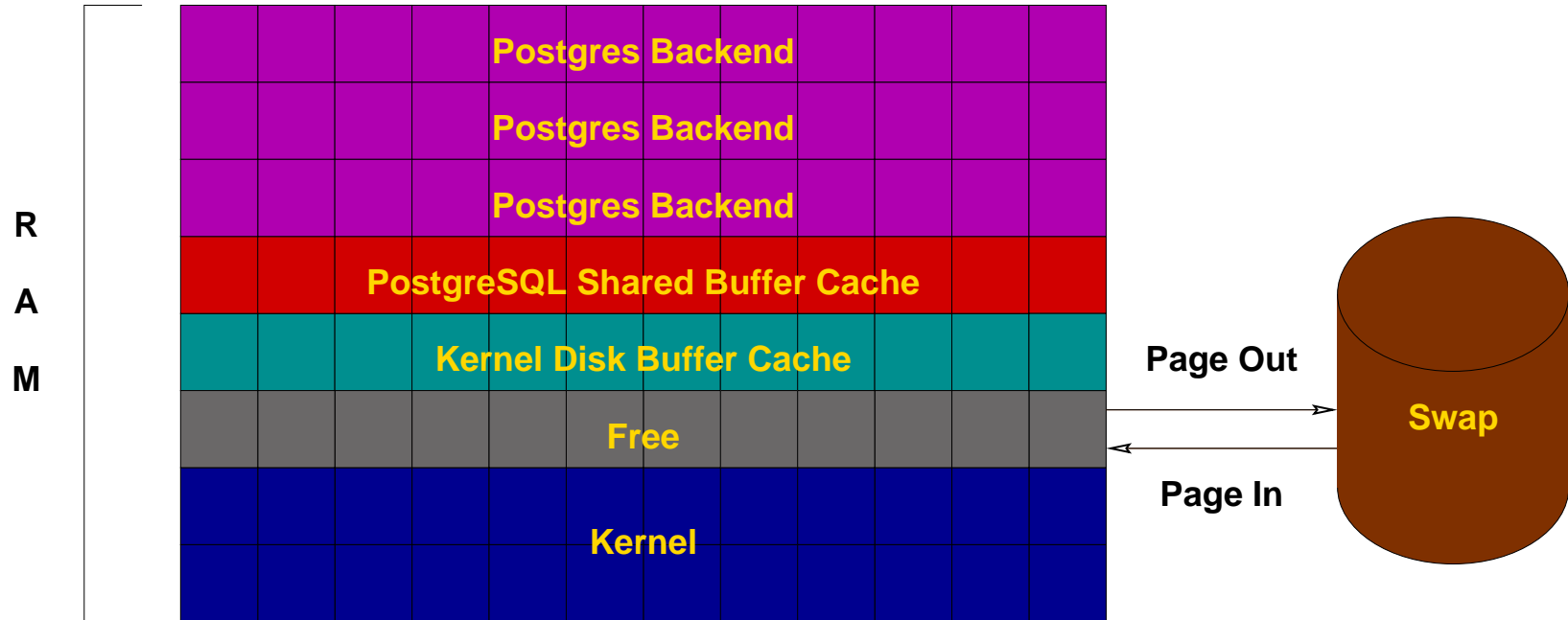

Postgresql.conf CACHE PARAMETERS

- Memory -

```
#shared_buffers = 1000          # min 16, at least max_connections*2, 8KB each
#work_mem = 1024                # min 64, size in KB
#maintenance_work_mem = 16384  # min 1024, size in KB
```

- Free Space Map -

```
#max_fsm_pages = 20000         # min max_fsm_relations*16, 6 bytes each
#max_fsm_relations = 1000     # min 100, ~50 bytes each
```

INTERNALS



SQL QUERY

```
SELECT firstname  
FROM friend  
WHERE age = 33;
```

QUERY IN PSQL

```
test=> SELECT firstname
test-> FROM friend
test-> WHERE age = 33;
      firstname
```

```
Sandy
(1 row)
```

QUERY PROCESSING

```
test=> SELECT firstname  
test-> FROM friend  
test-> WHERE age = 33;
```

```
[ query is processed ]
```

```
      firstname
```

```
-----
```

```
Sandy  
(1 row)
```

QUERY IN LIBPQ

```
test=> SELECT firstname
test-> FROM friend
test-> WHERE age = 33;
```

```
Breakpoint 1, PQexec (conn=0x807a000,
  query=0x8081200 "SELECT firstname\nFROM friend\nWHERE age = 33;")
at fe-exec.c:1195
```

LIBPQ

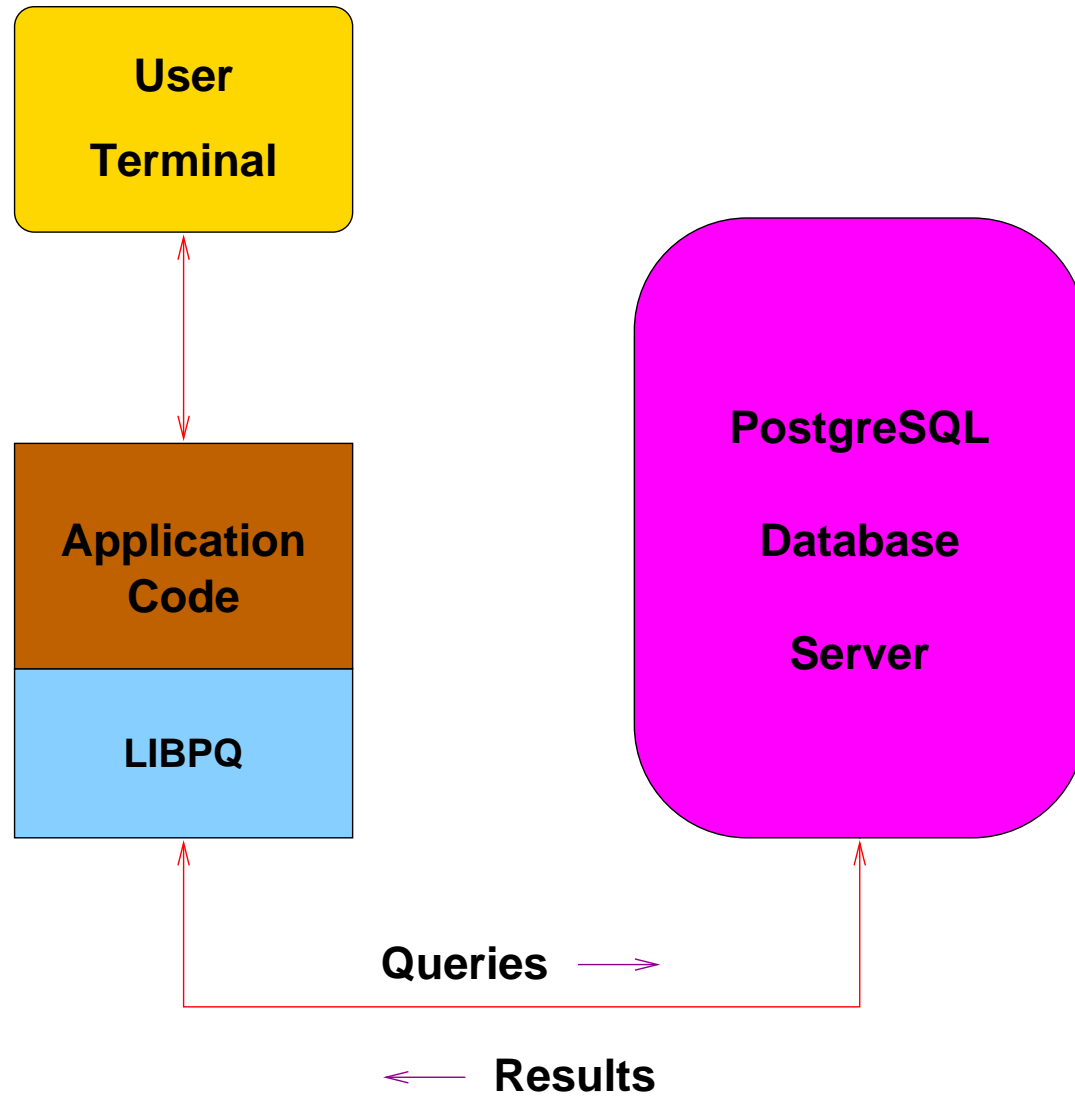

TCP/IP PACKET

17:05:22.715714 family.home.49165 > candle.navpoint.com.5432: P 354:400(46)
ack 61 win 8760 <nop,nop,timestamp 137847 7276138> (DF)

```
0000: 00 d0 b7 b9 b6 c8 00 02    b3 04 09 dd 08 00 45 00    _____ E_
0010: 00 62 45 31 40 00 40 06    b1 fe ac 14 00 02 a2 21    _bE1@_@_ _____!
0020: f5 2e c0 0d 15 38 1c af    94 34 a8 1a 1e 39 80 18    _._8_ _4_9_
0030: 22 38 19 d5 00 00 01 01    08 0a 00 02 1a 77 00 6f    "8_____w_o
0040: 06 6a 51 53 45 4c 45 43    54 20 66 69 72 73 74 6e    _jQSELEC T firstn
0050: 61 6d 65 0a 46 52 4f 4d    20 66 72 69 65 6e 64 0a    ame_FROM friend_
0060: 57 48 45 52 45 20 61 67    65 20 3d 20 33 33 3b 00    WHERE ag e = 33;_
```

QUERY SENT

RESULT RECEIVED

```
FindExec: found "/var/local/postgres/./bin/postgres" using argv[0]
DEBUG: connection: host=[local] user=postgres database=test
DEBUG: InitPostgres
DEBUG: StartTransactionCommand
DEBUG: query: SELECT firstname
             FROM friend
             WHERE age = 33;

[ query is processed ]

DEBUG: ProcessQuery
DEBUG: CommitTransactionCommand
DEBUG: proc_exit(0)
DEBUG: shm_exit(0)
DEBUG: exit(0)
```

QUERY PROCESSING

```
FindExec: found "/var/local/postgres/bin/postmaster" using argv[0]
./bin/postmaster: BackendStartup: pid 3320 user postgres db test socket 5
./bin/postmaster child[3320]: starting with (postgres -d99 -F -d99 -v131072 -p test )
FindExec: found "/var/local/postgres/bin/postgres" using argv[0]
DEBUG: connection: host=[local] user=postgres database=test
DEBUG: InitPostgres
DEBUG: StartTransactionCommand
DEBUG: query: SELECT firstname
        FROM friend
        WHERE age = 33;
DEBUG: parse tree: { QUERY :command 1 :utility <> :resultRelation 0 :into <> :isPortal false :isBinary false :isTemp false :hasAgg
s false :hasSubLinks false :rtable ({ RTE :relname friend :relid 26912 :subquery <> :alias <> :eref { ATTR :relname friend :attrs (
"firstname" "lastname" "city" "state" "age" )} :inh true :inFromCl true :checkForRead true :checkForWrite false :checkAsUse
r 0)} :jointree { FROMEXPR :fromlist ({ RANGETBLREF 1 )} :quals { EXPR :typeOid 16 :opType op :oper { OPER :opno 96 :opid 0 :opresu
ltype 16 } :args ({ VAR :varno 1 :varattno 5 :vartype 23 :vartypmod -1 :varlevelsup 0 :varnoold 1 :varoattno 5} { CONST :consttype
23 :constlen 4 :constbyval true :constisnull false :constvalue 4 [ 33 0 0 0 ] } )} } :rowMarks () :targetList ({ TARGETENTRY :resdom
{ RESDOM :resno 1 :restype 1042 :restypmod 19 :resname firstname :reskey 0 :reskeyop 0 :ressortgroupref 0 :resjunk false } :expr {
VAR :varno 1 :varattno 1 :vartype 1042 :vartypmod 19 :varlevelsup 0 :varnoold 1 :varoattno 1} )} :groupClause <> :havingQual <> :dis
tinctClause <> :sortClause <> :limitOffset <> :limitCount <> :setOperations <> :resultRelations ()}
DEBUG: rewritten parse tree:
DEBUG: { QUERY :command 1 :utility <> :resultRelation 0 :into <> :isPortal false :isBinary false :isTemp false :hasAggs false :has
SubLinks false :rtable ({ RTE :relname friend :relid 26912 :subquery <> :alias <> :eref { ATTR :relname friend :attrs ("firstname"
"lastname" "city" "state" "age" )} :inh true :inFromCl true :checkForRead true :checkForWrite false :checkAsUser 0)} :joint
ree { FROMEXPR :fromlist ({ RANGETBLREF 1 )} :quals { EXPR :typeOid 16 :opType op :oper { OPER :opno 96 :opid 0 :opresulttype 16 }
:args ({ VAR :varno 1 :varattno 5 :vartype 23 :vartypmod -1 :varlevelsup 0 :varnoold 1 :varoattno 5} { CONST :consttype 23 :constle
n 4 :constbyval true :constisnull false :constvalue 4 [ 33 0 0 0 ] } )} } :rowMarks () :targetList ({ TARGETENTRY :resdom { RESDOM :r
esno 1 :restype 1042 :restypmod 19 :resname firstname :reskey 0 :reskeyop 0 :ressortgroupref 0 :resjunk false } :expr { VAR :varno 1
:varattno 1 :vartype 1042 :vartypmod 19 :varlevelsup 0 :varnoold 1 :varoattno 1} )} :groupClause <> :havingQual <> :distinctClause
<> :sortClause <> :limitOffset <> :limitCount <> :setOperations <> :resultRelations ()}
DEBUG: plan: { SEQSCAN :startup_cost 0.00 :total_cost 22.50 :rows 10 :width 12 :qptargetlist ({ TARGETENTRY :resdom { RESDOM :resno
1 :restype 1042 :restypmod 19 :resname firstname :reskey 0 :reskeyop 0 :ressortgroupref 0 :resjunk false } :expr { VAR :varno 1 :va
rattno 1 :vartype 1042 :vartypmod 19 :varlevelsup 0 :varnoold 1 :varoattno 1} )} :qpqual ({ EXPR :typeOid 16 :opType op :oper { OPE
R :opno 96 :opid 65 :opresulttype 16 } :args ({ VAR :varno 1 :varattno 5 :vartype 23 :vartypmod -1 :varlevelsup 0 :varnoold 1 :varo
attno 5} { CONST :consttype 23 :constlen 4 :constbyval true :constisnull false :constvalue 4 [ 33 0 0 0 ] } )} )} :lefttree <> :rightt
ree <> :extprm () :locprm () :initplan <> :nprm 0 :scanrelid 1 }
DEBUG: ProcessQuery
DEBUG: CommitTransactionCommand
DEBUG: proc_exit(0)
DEBUG: shm_exit(0)
DEBUG: exit(0)
./bin/postmaster: reaping dead processes...
./bin/postmaster: CleanupProc: pid 3320 exited with status 0
```

BACKEND FLOWCHART

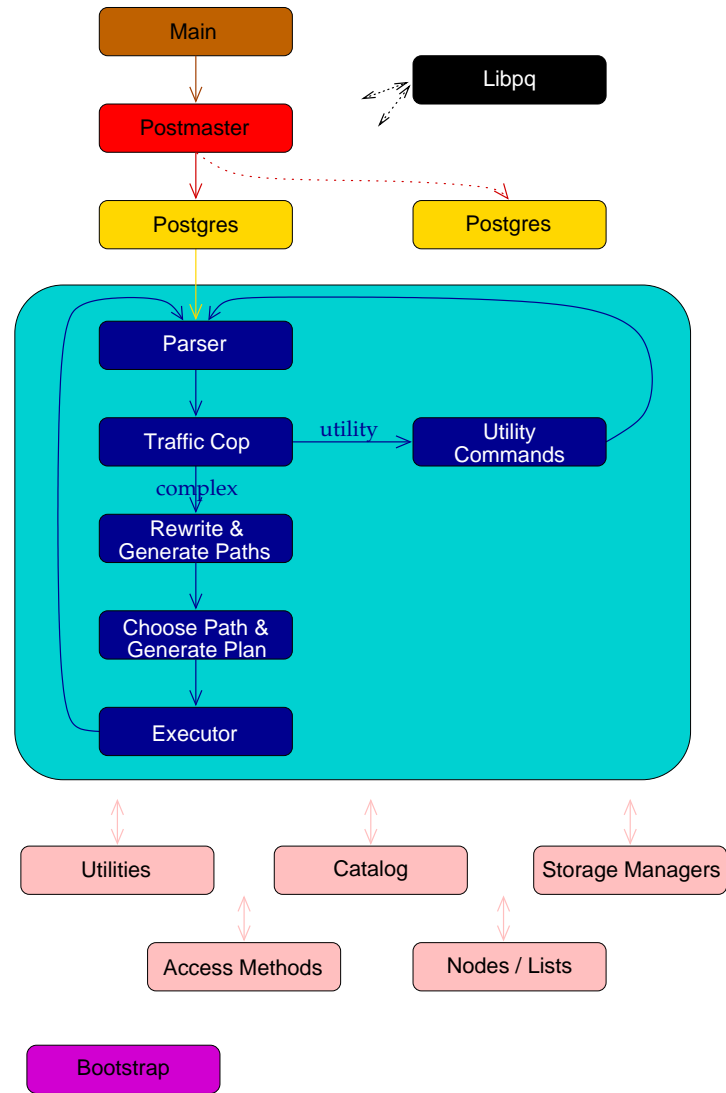

BACKEND FLOWCHART - MAGNIFIED

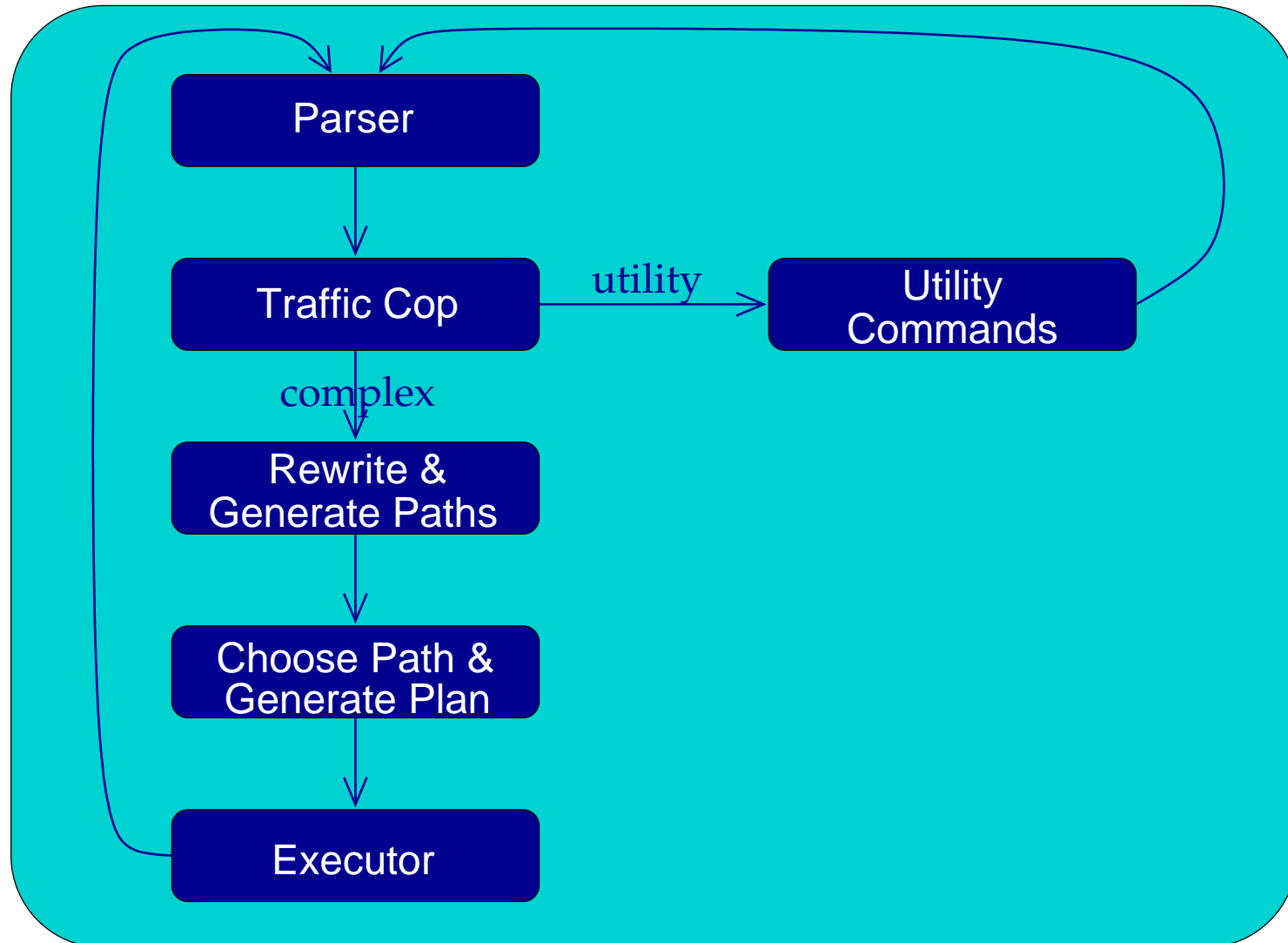

STATISTICS - PART 1

PARSER STATISTICS

system usage stats:

0.000002 elapsed 0.000000 user 0.000001 system sec
[0.009992 user 0.049961 sys total]
0/0 [0/1] filesystem blocks in/out
0/0 [0/0] page faults/reclaims, 0 [0] swaps
0 [0] signals rcvd, 0/0 [2/2] messages rcvd/sent
0/0 [2/6] voluntary/involuntary context switches

postgres usage stats:

Shared blocks:	0 read,	0 written,	buffer hit rate = 0.00%
Local blocks:	0 read,	0 written,	buffer hit rate = 0.00%
Direct blocks:	0 read,	0 written	

PARSE ANALYSIS STATISTICS

system usage stats:

0.000002 elapsed 0.000001 user 0.000002 system sec
[0.009993 user 0.049965 sys total]
0/0 [0/1] filesystem blocks in/out
0/0 [0/0] page faults/reclaims, 0 [0] swaps
0 [0] signals rcvd, 0/0 [2/2] messages rcvd/sent
0/0 [2/6] voluntary/involuntary context switches

postgres usage stats:

Shared blocks:	1 read,	0 written,	buffer hit rate = 96.88%
Local blocks:	0 read,	0 written,	buffer hit rate = 0.00%
Direct blocks:	0 read,	0 written	

STATISTICS - PART 2

REWRITER STATISTICS

system usage stats:

```
0.000002 elapsed 0.000000 user 0.000002 system sec
[0.009993 user 0.049968 sys total]
0/0 [0/1] filesystem blocks in/out
0/0 [0/0] page faults/reclaims, 0 [0] swaps
0 [0] signals rcvd, 0/0 [2/2] messages rcvd/sent
0/0 [2/6] voluntary/involuntary context switches
```

postgres usage stats:

```
Shared blocks:          0 read,          0 written, buffer hit rate = 0.00%
Local blocks:           0 read,          0 written, buffer hit rate = 0.00%
Direct blocks:          0 read,          0 written
```

PLANNER STATISTICS

system usage stats:

```
0.009974 elapsed 0.009988 user -1.999985 system sec
[0.019982 user 0.049955 sys total]
0/0 [0/1] filesystem blocks in/out
0/0 [0/0] page faults/reclaims, 0 [0] swaps
0 [0] signals rcvd, 0/0 [2/2] messages rcvd/sent
0/0 [2/6] voluntary/involuntary context switches
```

postgres usage stats:

```
Shared blocks:          5 read,          0 written, buffer hit rate = 96.69%
Local blocks:           0 read,          0 written, buffer hit rate = 0.00%
Direct blocks:          0 read,          0 written
```

EXECUTOR STATISTICS

system usage stats:

```
0.040004 elapsed 0.039982 user 0.000013 system sec
[0.059964 user 0.049970 sys total]
0/0 [0/1] filesystem blocks in/out
0/0 [0/0] page faults/reclaims, 0 [0] swaps
0 [0] signals rcvd, 0/2 [2/4] messages rcvd/sent
2/2 [4/8] voluntary/involuntary context switches
```

postgres usage stats:

```
Shared blocks:          2 read,          0 written, buffer hit rate = 83.33%
Local blocks:           0 read,          0 written, buffer hit rate = 0.00%
Direct blocks:          0 read,          0 written
```

OPTIMIZER

- SCAN METHODS
- JOIN METHODS
- JOIN ORDER

SCAN METHODS

- SEQUENTIAL SCAN
- INDEX SCAN

SEQUENTIAL SCAN

Heap



D	D	D	D	D	D	D	D	D	D	D	D
A	A	A	A	A	A	A	A	A	A	A	A
T	T	T	T	T	T	T	T	T	T	T	T
A	A	A	A	A	A	A	A	A	A	A	A



8K

BTREE INDEX SCAN

Index



Heap

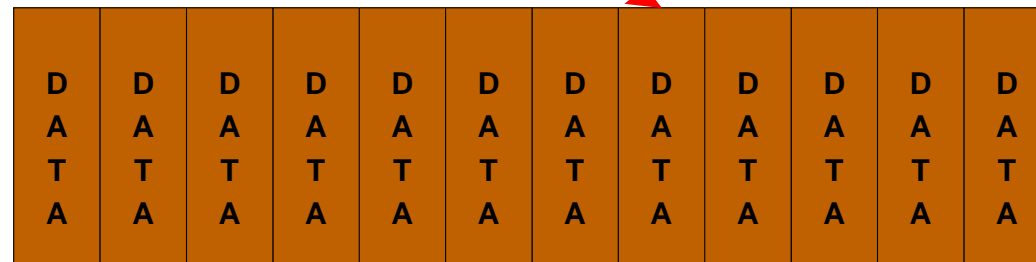

BITMAP SCAN

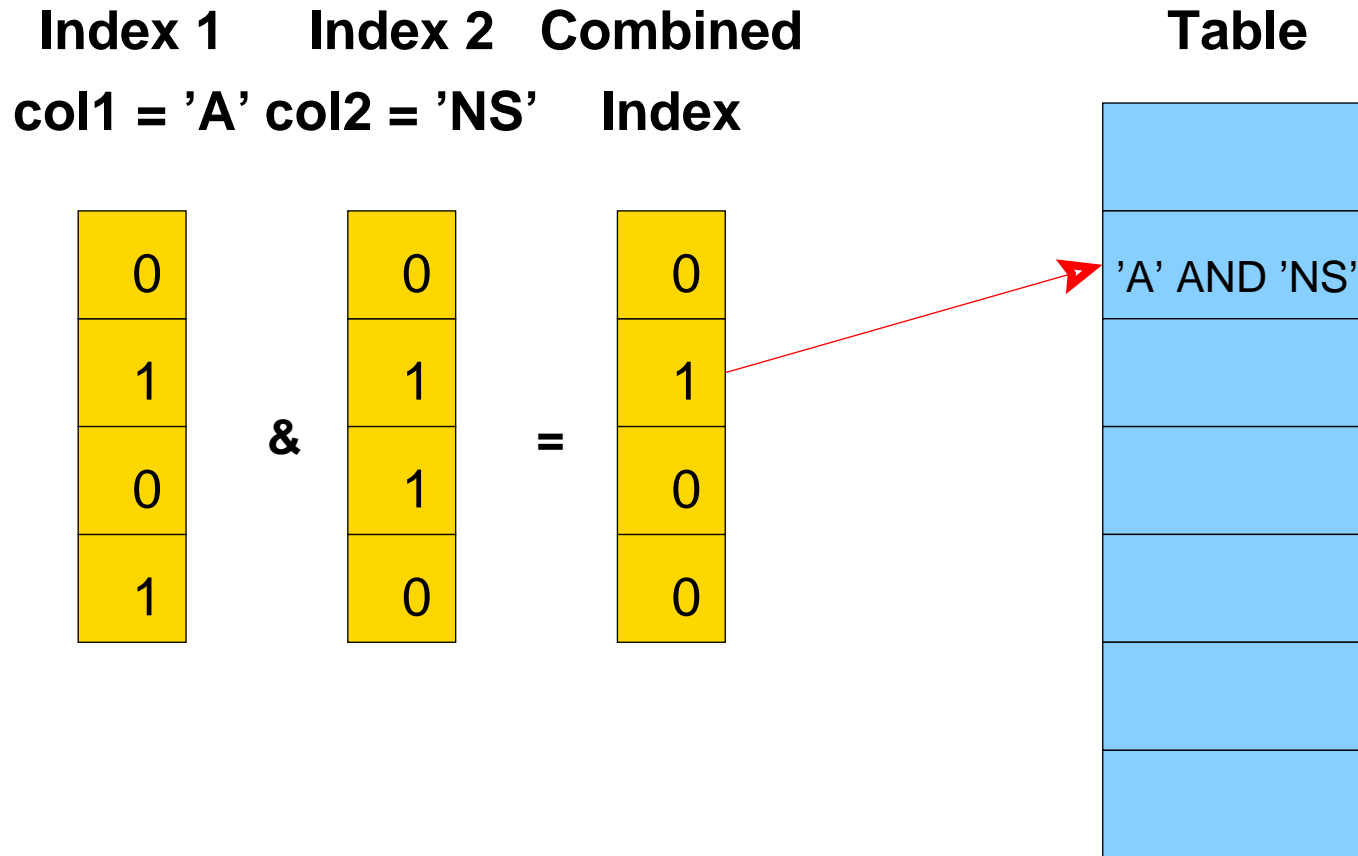

JOIN METHODS

- NESTED LOOP WITH SEQUENTIAL SCAN
- NESTED LOOP WITH INDEX SCAN
- MERGE JOIN
- HASH JOIN

NESTED LOOP JOIN WITH SEQUENTIAL SCAN

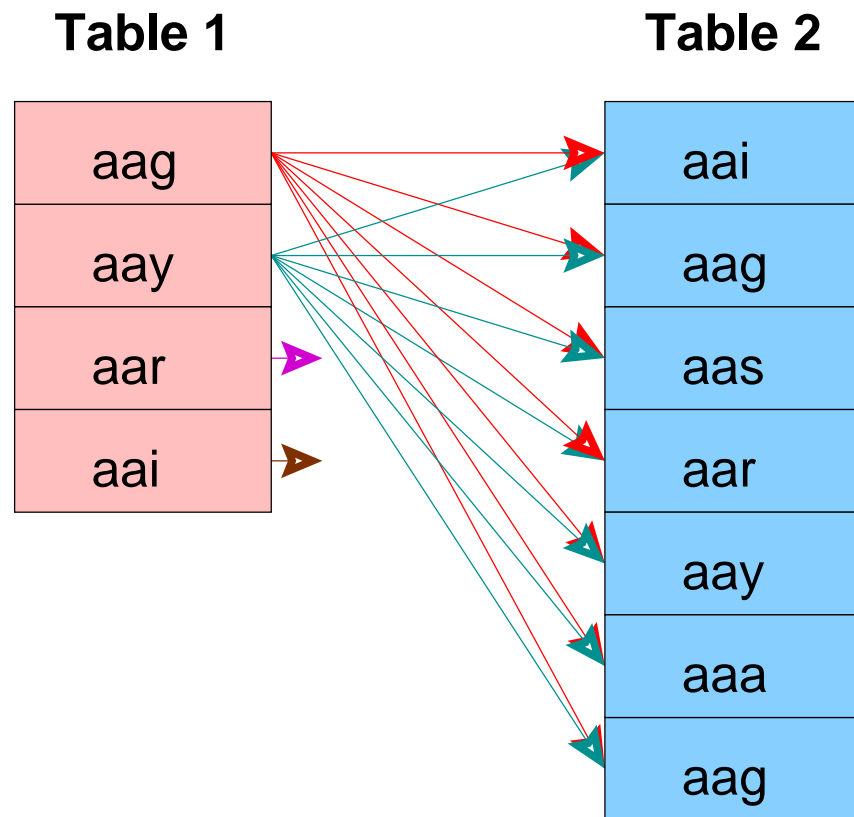

No Setup Required

Used For Small Tables

NESTED LOOP JOIN WITH INDEX SCAN

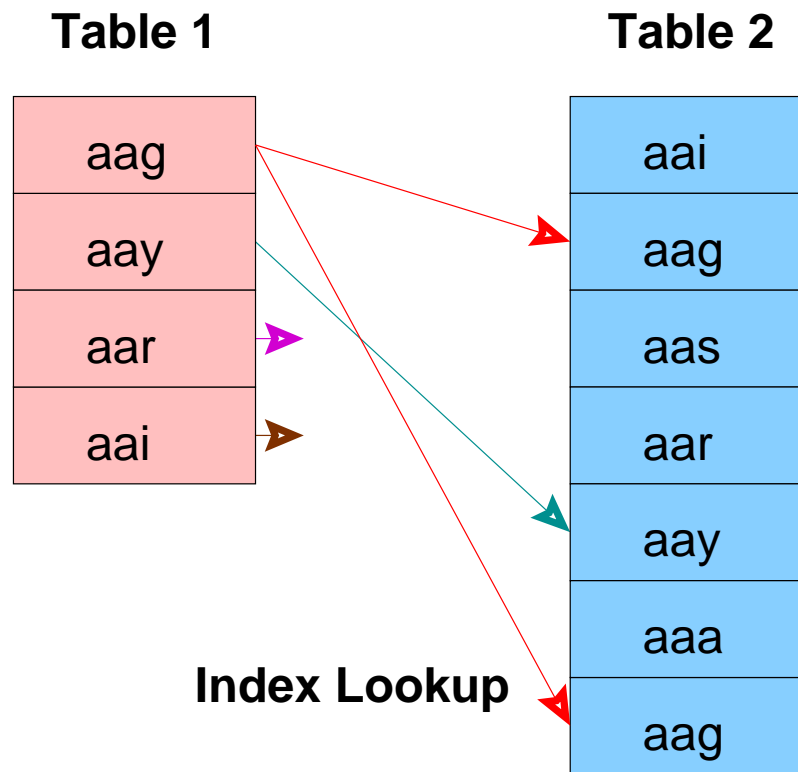

No Setup Required

Index Must Already Exist

MERGE JOIN

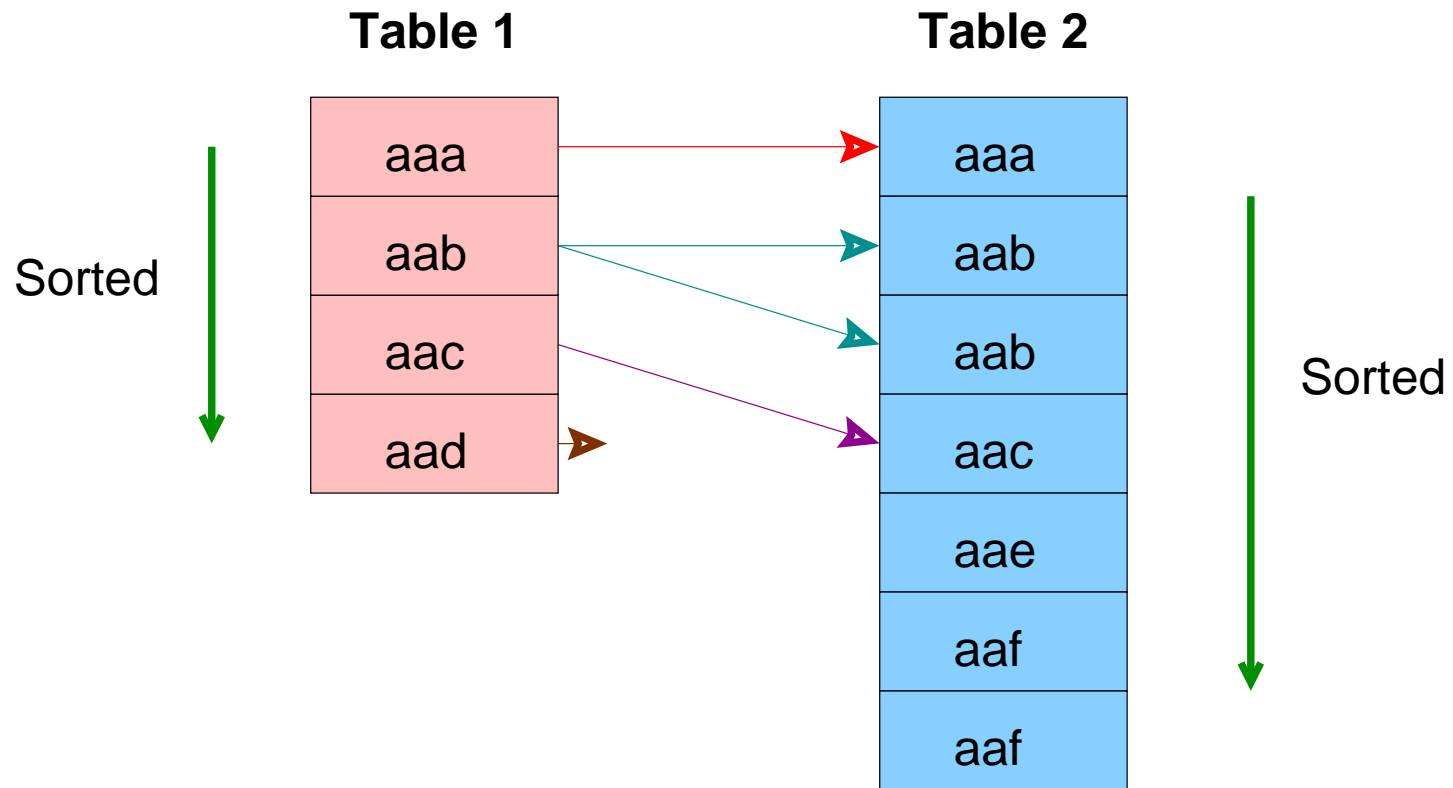

Ideal for Large Tables

An Index Can Be Used to Eliminate the Sort

HASH JOIN

Table 1

aay
aag
aak
aar

Table 2

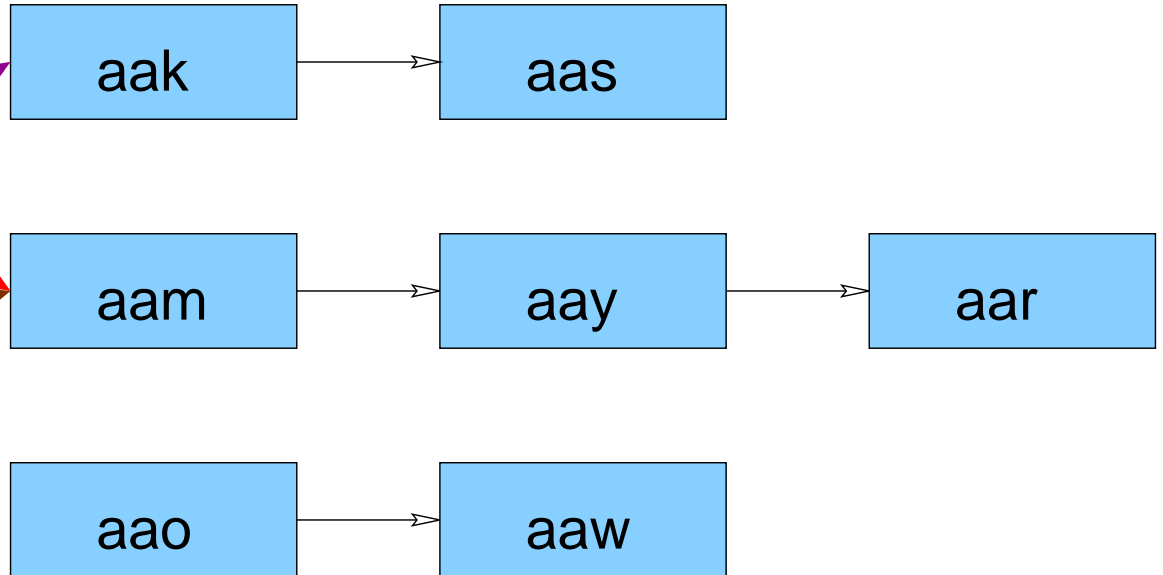

Hashed
→



Must fit in Main Memory

THREE-TABLE JOIN QUERY

```
SELECT part.price  
FROM customer, salesorder, part  
WHERE customer.customer_id = salesorder.customer_id AND  
salesorder.part = part.part_id
```

THREE-TABLE JOIN, PASS 1, PART 1

```
( 2 3 ): rows=575 width=76
path list:
HashJoin rows=575 cost=3.57..41.90
  clauses=(salesorder.part_id = part.part_id)
    SeqScan(2) rows=575 cost=0.00..13.75
    SeqScan(3) rows=126 cost=0.00..3.26
Nestloop rows=575 cost=0.00..1178.70
  SeqScan(2) rows=575 cost=0.00..13.75
  IdxScan(3) rows=126 cost=0.00..2.01
Nestloop rows=575 cost=0.00..1210.28
  pathkeys=((salesorder.customer_id, customer.customer_id) )
  IdxScan(2) rows=575 cost=0.00..45.33
  pathkeys=((salesorder.customer_id, customer.customer_id) )
  IdxScan(3) rows=126 cost=0.00..2.01

cheapest startup path:
Nestloop rows=575 cost=0.00..1178.70
  SeqScan(2) rows=575 cost=0.00..13.75
  IdxScan(3) rows=126 cost=0.00..2.01

cheapest total path:
HashJoin rows=575 cost=3.57..41.90
  clauses=(salesorder.part_id = part.part_id)
    SeqScan(2) rows=575 cost=0.00..13.75
    SeqScan(3) rows=126 cost=0.00..3.26
```

THREE-TABLE JOIN, PASS 1, PART 2

```
(1 2 ): rows=575 width=76
path list:
HashJoin rows=575 cost=3.00..40.75
  clauses=(salesorder.customer_id = customer.customer_id)
    SeqScan(2) rows=575 cost=0.00..13.75
    SeqScan(1) rows=80 cost=0.00..2.80
MergeJoin rows=575 cost=0.00..64.39
  clauses=(salesorder.customer_id = customer.customer_id)
    IdxScan(1) rows=80 cost=0.00..10.88
    pathkeys=((salesorder.customer_id, customer.customer_id) )
    IdxScan(2) rows=575 cost=0.00..45.33
    pathkeys=((salesorder.customer_id, customer.customer_id) )

cheapest startup path:
MergeJoin rows=575 cost=0.00..64.39
  clauses=(salesorder.customer_id = customer.customer_id)
    IdxScan(1) rows=80 cost=0.00..10.88
    pathkeys=((salesorder.customer_id, customer.customer_id) )
    IdxScan(2) rows=575 cost=0.00..45.33
    pathkeys=((salesorder.customer_id, customer.customer_id) )

cheapest total path:
HashJoin rows=575 cost=3.00..40.75
  clauses=(salesorder.customer_id = customer.customer_id)
    SeqScan(2) rows=575 cost=0.00..13.75
    SeqScan(1) rows=80 cost=0.00..2.80
```

THREE-TABLE JOIN, PASS 2, PART 1

```
( 2 3 1 ): rows=575 width=112
path list:
HashJoin rows=575 cost=6.58..68.90
  clauses=(salesorder.customer_id = customer.customer_id)
    HashJoin rows=575 cost=3.57..41.90
      clauses=(salesorder.part_id = part.part_id)
        SeqScan(2) rows=575 cost=0.00..13.75
        SeqScan(3) rows=126 cost=0.00..3.26
      SeqScan(1) rows=80 cost=0.00..2.80
    HashJoin rows=575 cost=3.57..92.54
      clauses=(salesorder.part_id = part.part_id)
        MergeJoin rows=575 cost=0.00..64.39
          clauses=(salesorder.customer_id = customer.customer_id)
            IdxScan(1) rows=80 cost=0.00..10.88
              pathkeys=((salesorder.customer_id, customer.customer_id) )
            IdxScan(2) rows=575 cost=0.00..45.33
              pathkeys=((salesorder.customer_id, customer.customer_id) )
          SeqScan(3) rows=126 cost=0.00..3.26
        HashJoin rows=575 cost=3.00..1205.70
          clauses=(salesorder.customer_id = customer.customer_id)
            Nestloop rows=575 cost=0.00..1178.70
              SeqScan(2) rows=575 cost=0.00..13.75
              IdxScan(3) rows=126 cost=0.00..2.01
            SeqScan(1) rows=80 cost=0.00..2.80
```

THREE-TABLE JOIN, PASS 2, PART 2

```
MergeJoin rows=575 cost=0.00..1229.35
  clauses=(salesorder.customer_id = customer.customer_id)
    Nestloop rows=575 cost=0.00..1210.28
      pathkeys=((salesorder.customer_id, customer.customer_id) )
        IdxScan(2) rows=575 cost=0.00..45.33
          pathkeys=((salesorder.customer_id, customer.customer_id) )
            IdxScan(3) rows=126 cost=0.00..2.01
              IdxScan(1) rows=80 cost=0.00..10.88
                pathkeys=((salesorder.customer_id, customer.customer_id) )
```

cheapest startup path:

```
MergeJoin rows=575 cost=0.00..1229.35
  clauses=(salesorder.customer_id = customer.customer_id)
    Nestloop rows=575 cost=0.00..1210.28
      pathkeys=((salesorder.customer_id, customer.customer_id) )
        IdxScan(2) rows=575 cost=0.00..45.33
          pathkeys=((salesorder.customer_id, customer.customer_id) )
            IdxScan(3) rows=126 cost=0.00..2.01
              IdxScan(1) rows=80 cost=0.00..10.88
                pathkeys=((salesorder.customer_id, customer.customer_id) )
```

cheapest total path:

```
HashJoin rows=575 cost=6.58..68.90
  clauses=(salesorder.customer_id = customer.customer_id)
    HashJoin rows=575 cost=3.57..41.90
      clauses=(salesorder.part_id = part.part_id)
        SeqScan(2) rows=575 cost=0.00..13.75
          SeqScan(3) rows=126 cost=0.00..3.26
            SeqScan(1) rows=80 cost=0.00..2.80
```

RESULT RETURNED

```
test=> SELECT firstname
test-> FROM friend
test-> WHERE age = 33;
```

```
1: firstname          (typeid = 1042, len = -1, typmod = 19, byval = f)
```

```
-----
```

```
1: firstname = "Sandy" (typeid = 1042, len = -1, typmod = 19, byval = f)
```

```
-----
```

```
firstname
```

```
-----
```

```
Sandy
(1 row)
```

VACUUM ANALYZE

```
test=> VACUUM ANALYZE VERBOSE customer;
INFO:  vacuuming "pg_catalog.pg_depend"
INFO:  index "pg_depend_depender_ -
index" now contains 3616 row versions in 19 pages
DETAIL:  0 index pages have been deleted, 0 are currently reusable.
CPU 0.00s/0.00u sec elapsed 0.00 sec.
INFO:  index "pg_depend_reference_ -
index" now contains 3616 row versions in 23 pages
DETAIL:  0 index pages have been deleted, 0 are currently reusable.
CPU 0.00s/0.00u sec elapsed 0.00 sec.
INFO:  "pg_depend": found 0 removable, 3616 nonremovable row ver-
sions in 25 pages
DETAIL:  0 dead row versions cannot be removed yet.
There were 9 unused item pointers.
0 pages are entirely empty.
CPU 0.00s/-1.99u sec elapsed 0.00 sec.
```

```
INFO: analyzing "pg_catalog.pg_depend"  
INFO: "pg_  
depend": 25 pages, 3000 rows sampled, 3625 estimated total rows  
VACUUM
```



```

stanumbers3 | {-0.145569}
stanumbers4 |
stavalues1  | {I/O,equal,"not equal",less-than,greater-
than,greater-than-or-equal,less-than-or-equal
,subtract,multiply,add}
stavalues2  | {"(Block, offset), physical location of tu-
ple","absolute value","btree less-equal-grea
ter","convert int2 to float4","deparse an encoded expres-
sion","format int8 to text","is opclass visi-
ble in search path?","matches LIKE expres-
sion","print type names of oidvector field",sine,"~18 digit
integer, 8-byte storage"}
stavalues3  |
stavalues4  |

```

EXPLAIN

```
test=> EXPLAIN SELECT name FROM customer;
```

```
NOTICE: QUERY PLAN:
```

```
Seq Scan on customer (cost=0.00..225.88 rows=12288 width=34)
```

```
EXPLAIN
```

```
VACUUM
```

EXPLAIN ANALYZE

```
test=> EXPLAIN ANALYZE SELECT name FROM customer;
```

```
NOTICE: QUERY PLAN:
```

```
Seq Scan on customer (cost=0.00..225.88 rows=12288 width=34) (ac-  
tual time=0.21..205.20 rows=12288 loops=1)
```

```
Total runtime: 249.10 msec
```

```
EXPLAIN
```

EXPLAIN USING ANSI JOINS

```
test=> EXPLAIN INSERT INTO warehouse_tmp
test-> (uri, expression, n, relevance, spid_measure, size, title, sample)
test-> SELECT d.uri, dn.expression, n.n, dn.relevance, d.spid_measure,
test->      d.size, d.title, dn.sample
test-> FROM document as d
test->      INNER JOIN (document_n_gram AS dn
test(>      INNER JOIN n_gram AS n
test(>      ON (dn.expression = n.expression))
test->      ON (d.uri = dn.uri)
test-> ORDER BY dn.expression, n.n;
NOTICE: QUERY PLAN:
Subquery Scan *SELECT* (cost=3895109.07..3895109.07 rows=1009271 width=886)
-> Sort (cost=3895109.07..3895109.07 rows=1009271 width=886)
    -> Hash Join (cost=1155071.81..2115045.12 rows=1009271 width=886)
        -> Merge Join (cost=1154294.92..1170599.85 rows=1009271 width=588)
            -> Sort (cost=1001390.67..1001390.67 rows=1009271 width=439)
                -> Seq Scan on document_n_gram dn
                    (cost=0.00..49251.71 rows=1009271 width=439)
            -> Sort (cost=152904.25..152904.25 rows=466345 width=149)
                -> Seq Scan on n_gram n (cost=0.00..12795.45 rows=466345 width=149)
        -> Hash (cost=767.71..767.71 rows=3671 width=298)
            -> Seq Scan on document d (cost=0.00..767.71 rows=3671 width=298)
```

EXPLAIN

EXPLAIN USING SUBSELECT IN FROM CLAUSE

```
test=> EXPLAIN SELECT cs.entity_id as region, r.name, cs.status, count(*)
test-> FROM region r inner join
test->     (SELECT DISTINCT findregion(entity_id) AS entity_id, status
test(>     FROM current_status
test(>     ORDER BY 1
test(>     ) AS cs on r.region_id = cs.entity_id
test-> GROUP BY region, r.name, cs.status;
```

NOTICE: QUERY PLAN:

```
Aggregate (cost=13688.40..14338.40 rows=6500 width=24)
-> Group (cost=13688.40..14175.90 rows=65000 width=24)
  -> Sort (cost=13688.40..13688.40 rows=65000 width=24)
    -> Merge Join (cost=7522.19..7674.94 rows=65000 width=24)
      -> Index Scan using region_pkey on region r
          (cost=0.00 59.00 rows=1000 width=16)
      -> Sort (cost=7522.19..7522.19 rows=6500 width=8)
          -> Subquery Scan cs (cost=6785.54..7110.54
              rows=65 width=8)
              -> Unique (cost=6785.54..7110.54 rows=6500
                  with=8)
                  -> Sort (cost=6785.54..6785.54 rows=650
                      width=8)
                      -> Seq Scan on current_status
                          (st=0.00..1065.00 rows=65000 width=8)
```

EXPLAIN

Postgresql.conf OPTIMIZER PARAMETERS

- Planner Method Enabling -

```
#enable_hashagg = true
#enable_hashjoin = true
#enable_indexscan = true
#enable_mergejoin = true
#enable_nestloop = true
#enable_seqscan = true
#enable_sort = true
#enable_tidscan = true
```

- Planner Cost Constants -

```
#effective_cache_size = 1000    # typically 8KB each
#random_page_cost = 4          # units are one sequential page fetch cost
#cpu_tuple_cost = 0.01         # (same)
#cpu_index_tuple_cost = 0.001  # (same)
#cpu_operator_cost = 0.0025    # (same)
```

MORE Postgresql.conf OPTIMIZER PARAMETERS

- Genetic Query Optimizer -

#geqo = true

#geqo_threshold = 11

#geqo_effort = 1

#geqo_generations = 0

#geqo_pool_size = 0 # default based on tables in statement,
range 128-1024

#geqo_selection_bias = 2.0 # range 1.5-2.0

- Other Planner Options -

#default_statistics_target = 10 # range 1-1000

#from_collapse_limit = 8

#join_collapse_limit = 8 # 1 disables collapsing of explicit JOINS

STORAGE



FILE STRUCTURE

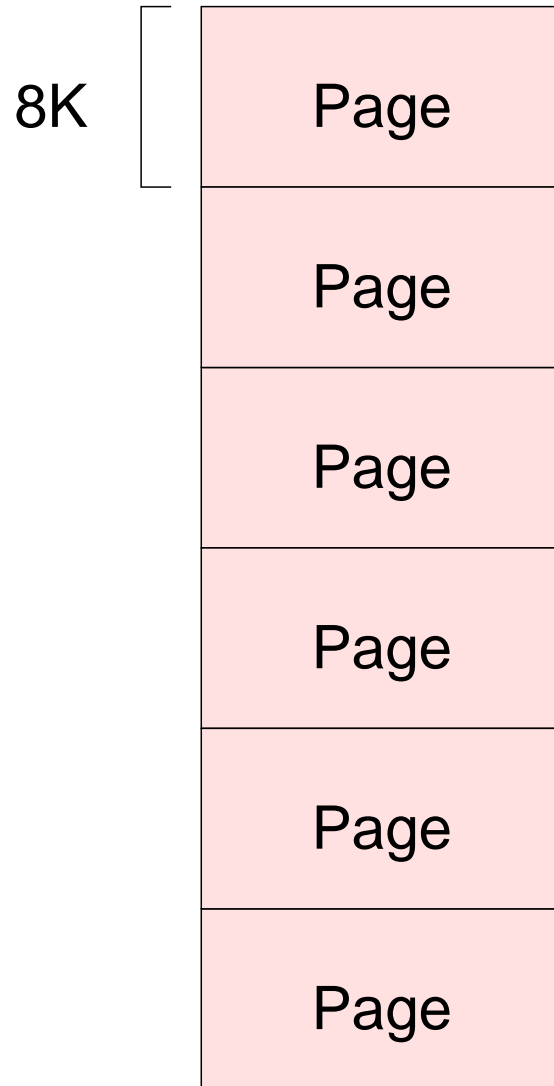

PAGE STRUCTURE

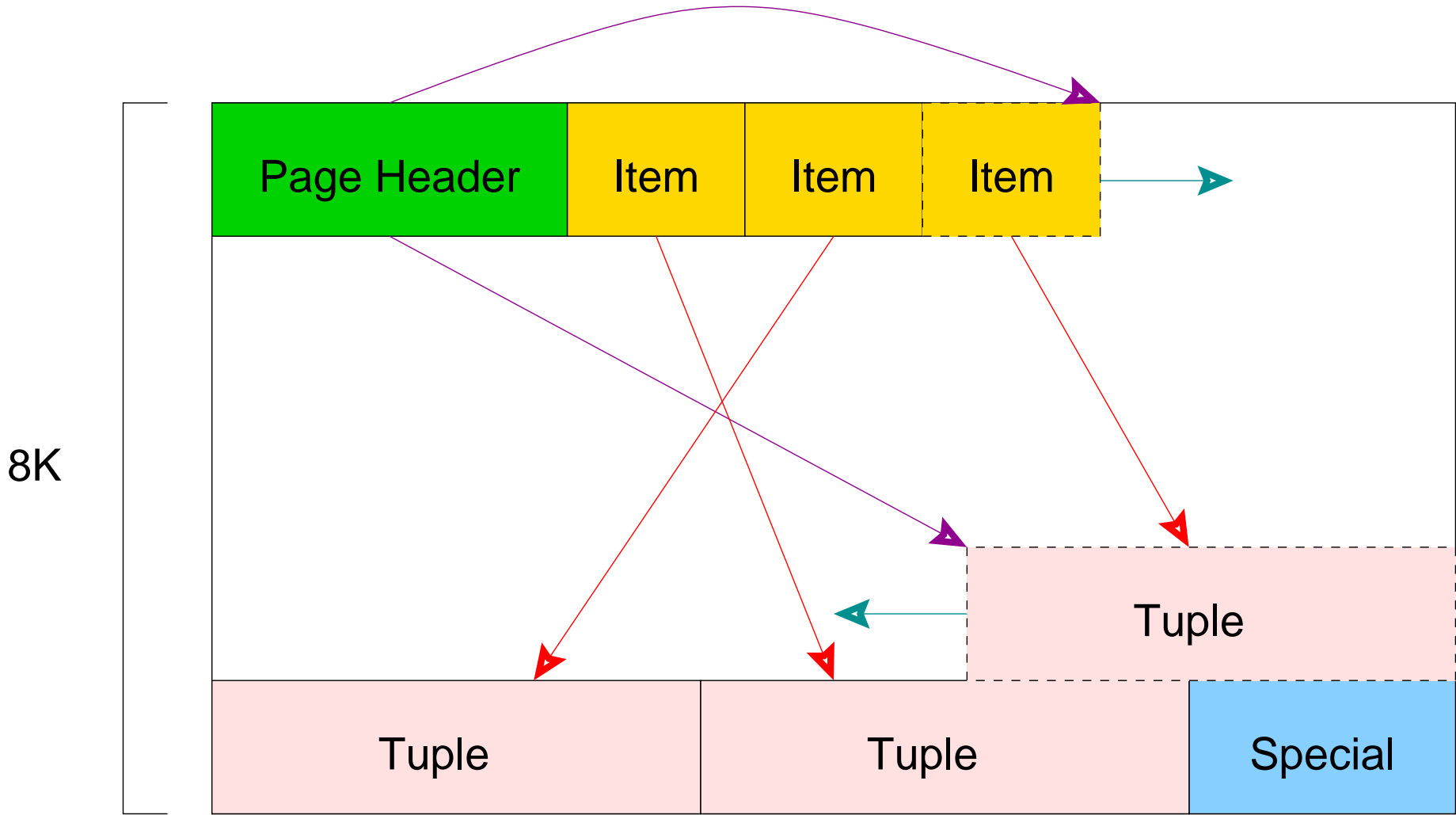

INDEX PAGE STRUCTURE

Internal

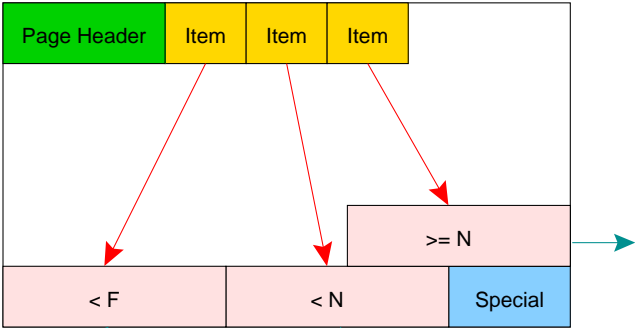

Leaf

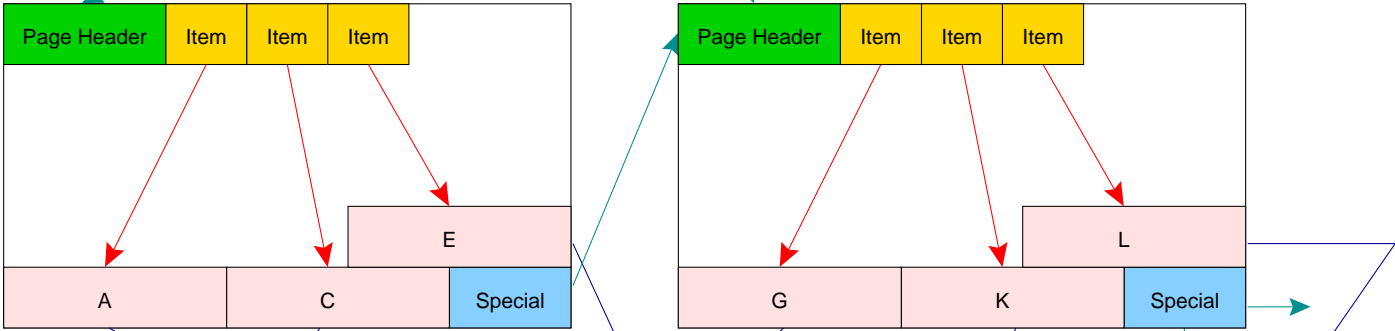

Heap



CLUSTER

Internal

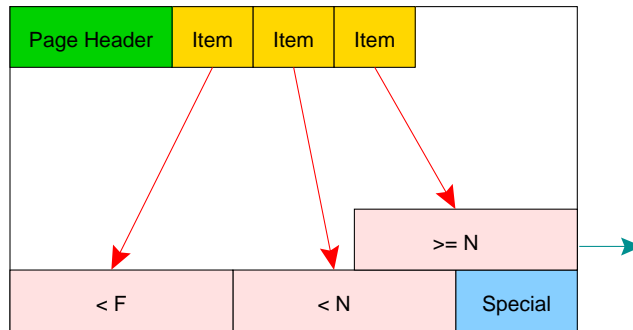

Leaf

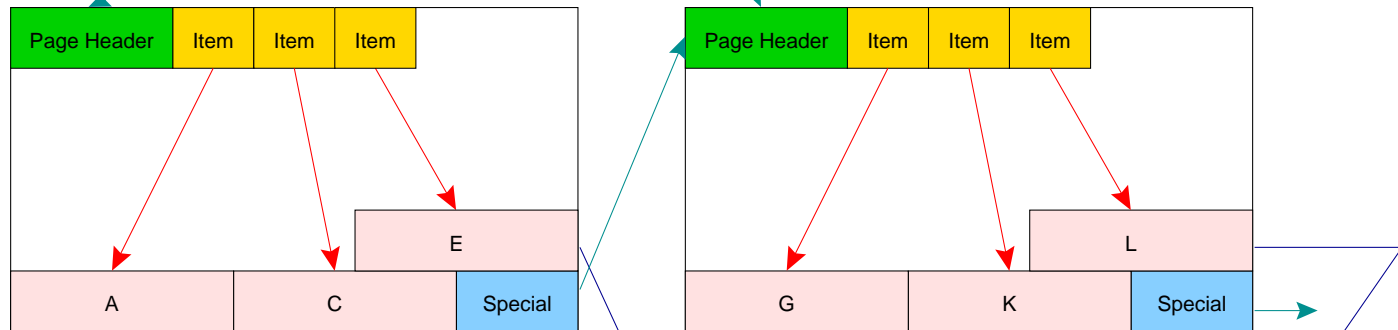

Heap



CLUSTER

```
test=> CREATE TABLE customer (id SERIAL, name TEXT);
NOTICE: CREATE TABLE will create implicit sequence 'customer_id_
seq' for SERIAL column 'customer.id'
test=> CREATE INDEX customer_id_index ON customer (id);
CREATE INDEX
test=> CLUSTER customer_id_index ON customer;
CLUSTER
```

INDEX TYPES (ACCESS METHODS)

- BTREE
- HASH
- RTREE

TABLESPACES FOR DATABASE I/O BALANCING

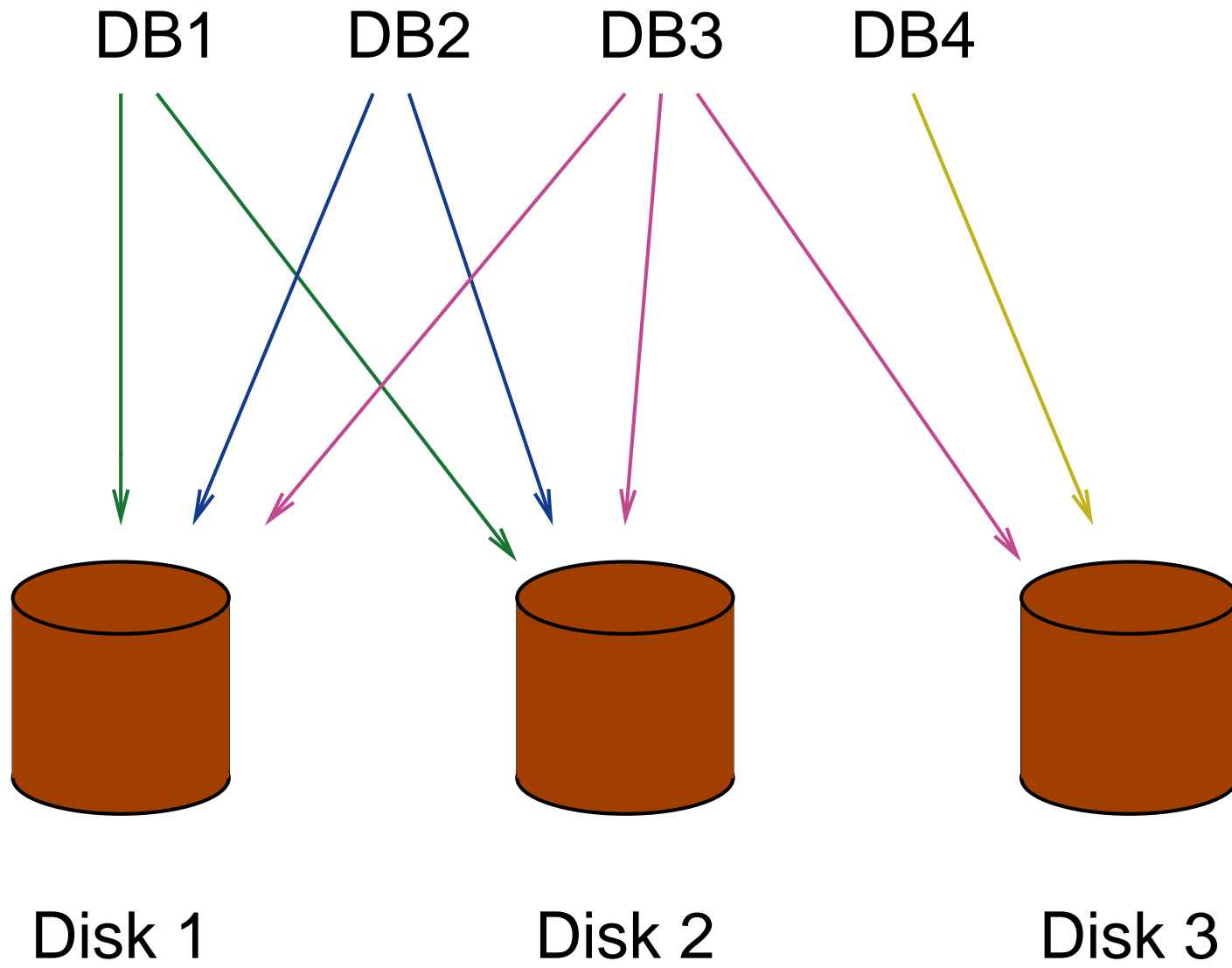
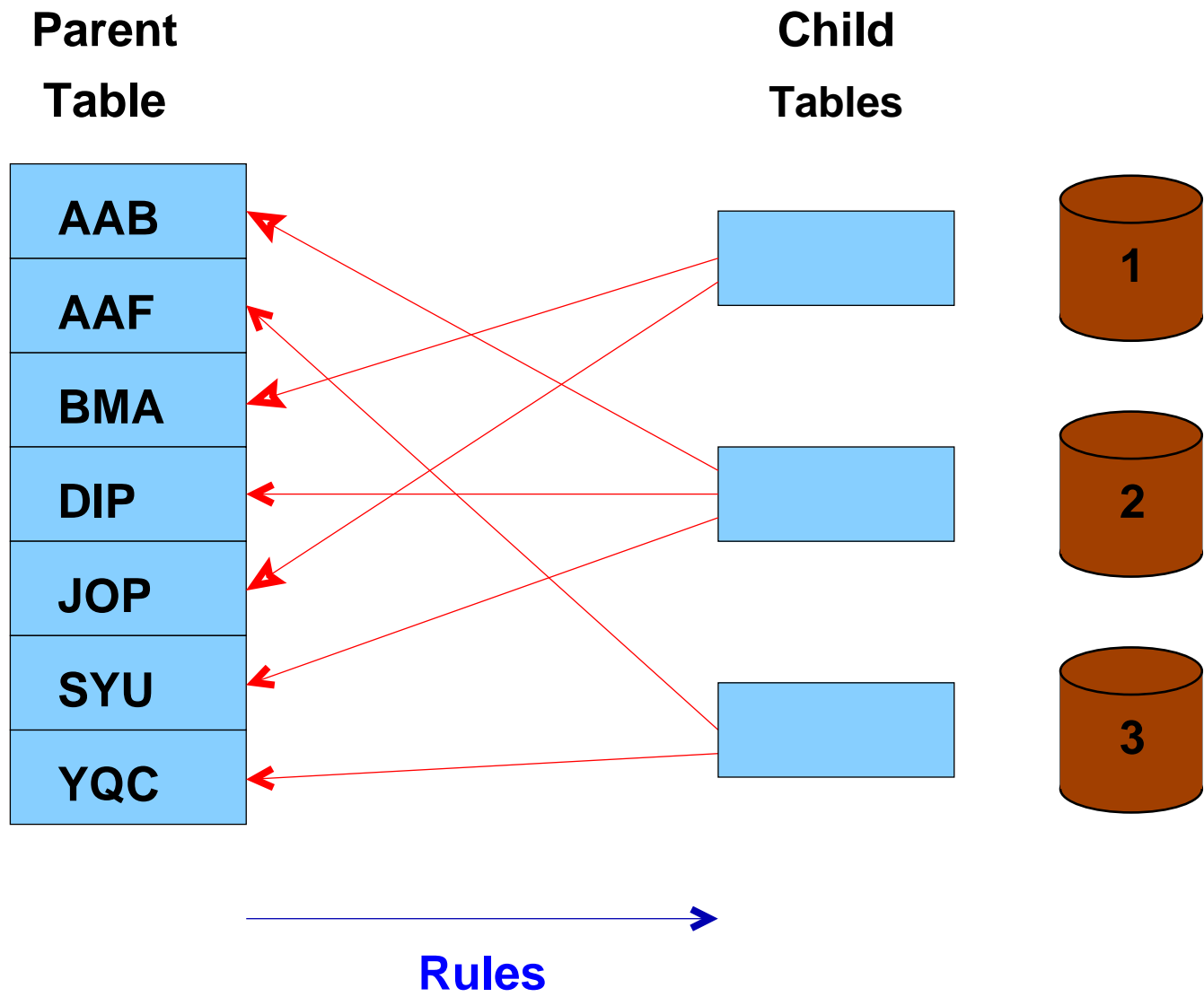

TABLE I/O BALANCING USING CONSTRAINT_EXCLUSION



RANGE PARTITIONING IS ALSO POSSIBLE.
POSTGRESQL PERFORMANCE TUNING

MANUAL AND AUTOMATIC VACUUM

Free Space Map

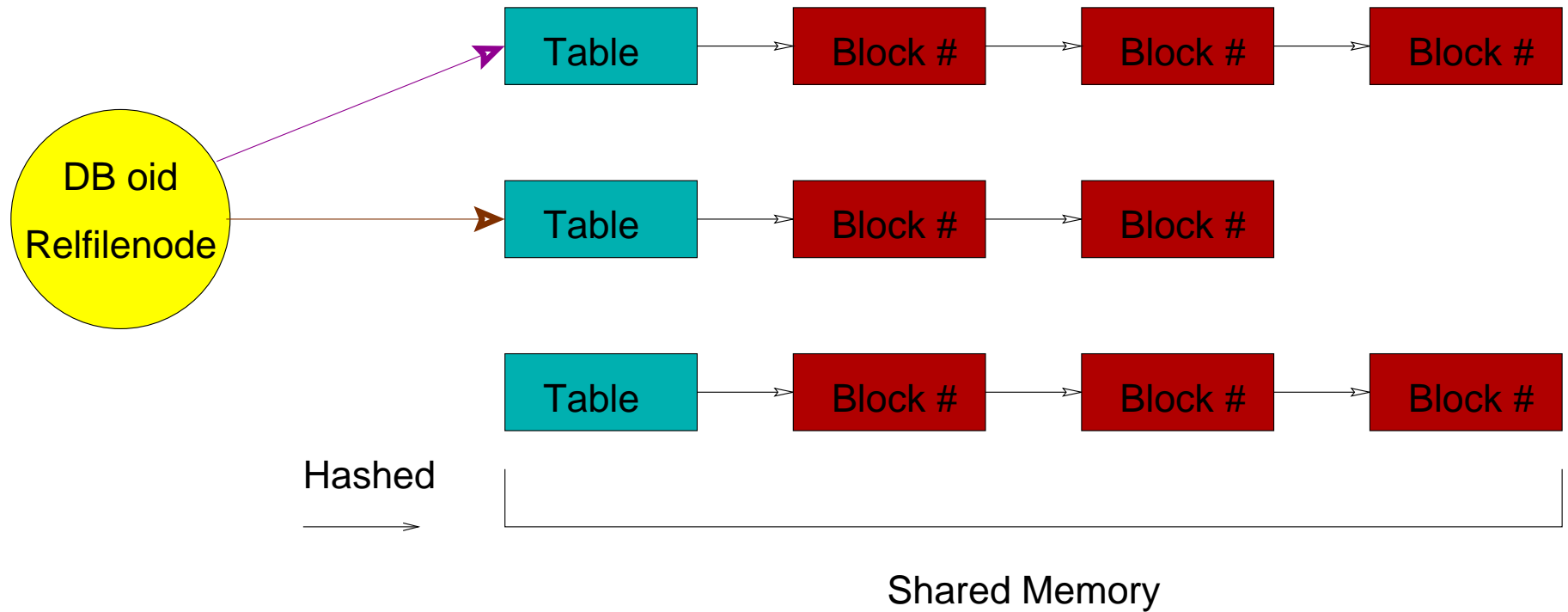

VACUUM FULL

Original Heap
With Expired
Rows Identified

A	A	E	A	A	A	E	A	A	A	A	A
C	C	X	C	C	C	X	C	C	C	C	C
T	T	P	T	T	T	P	T	T	T	T	T
I	I	I	I	I	I	I	I	I	I	I	I
V	V	R	V	V	V	R	V	V	V	V	V
E	E	E	E	E	E	E	E	E	E	E	E

Move Trailing
Rows Into Expired
Slots

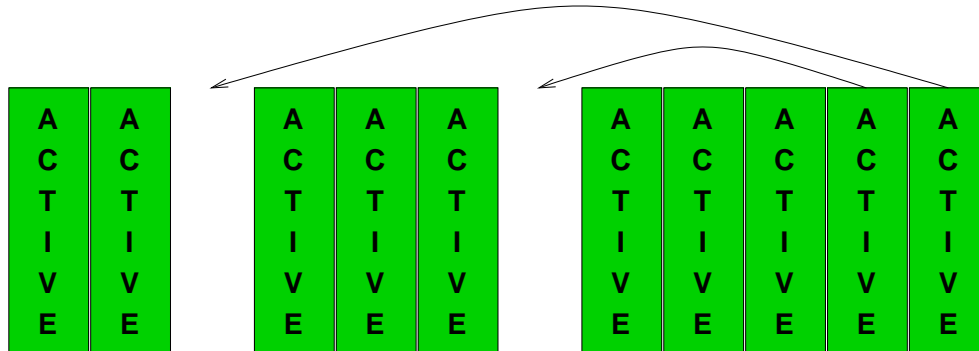

Truncate File

A	A	A	A	A	A	A	A	A	A		
C	C	C	C	C	C	C	C	C	C		
T	T	T	T	T	T	T	T	T	T		
I	I	I	I	I	I	I	I	I	I		
V	V	V	V	V	V	V	V	V	V		
E	E	E	E	E	E	E	E	E	E		

CACHES

- SYSTEM CACHE
- RELATION INFORMATION CACHE
- FILE DESCRIPTOR CACHE

SHARED MEMORY

- PROC STRUCTURE
- LOCK STRUCTURE
- BUFFER STRUCTURE
- FREE SPACE MAP

QUERY TIPS

- COPY VS. INSERT
- LIMIT VS. CURSOR
- DELETE VS. TRUNCATE
- FUNCTIONAL INDEXES
- PARTIAL INDEXES
- PREPARED QUERIES
- INTERSECT VS. AND (SELFJOIN)
- UNION VS. OR

SYSTEM TABLES

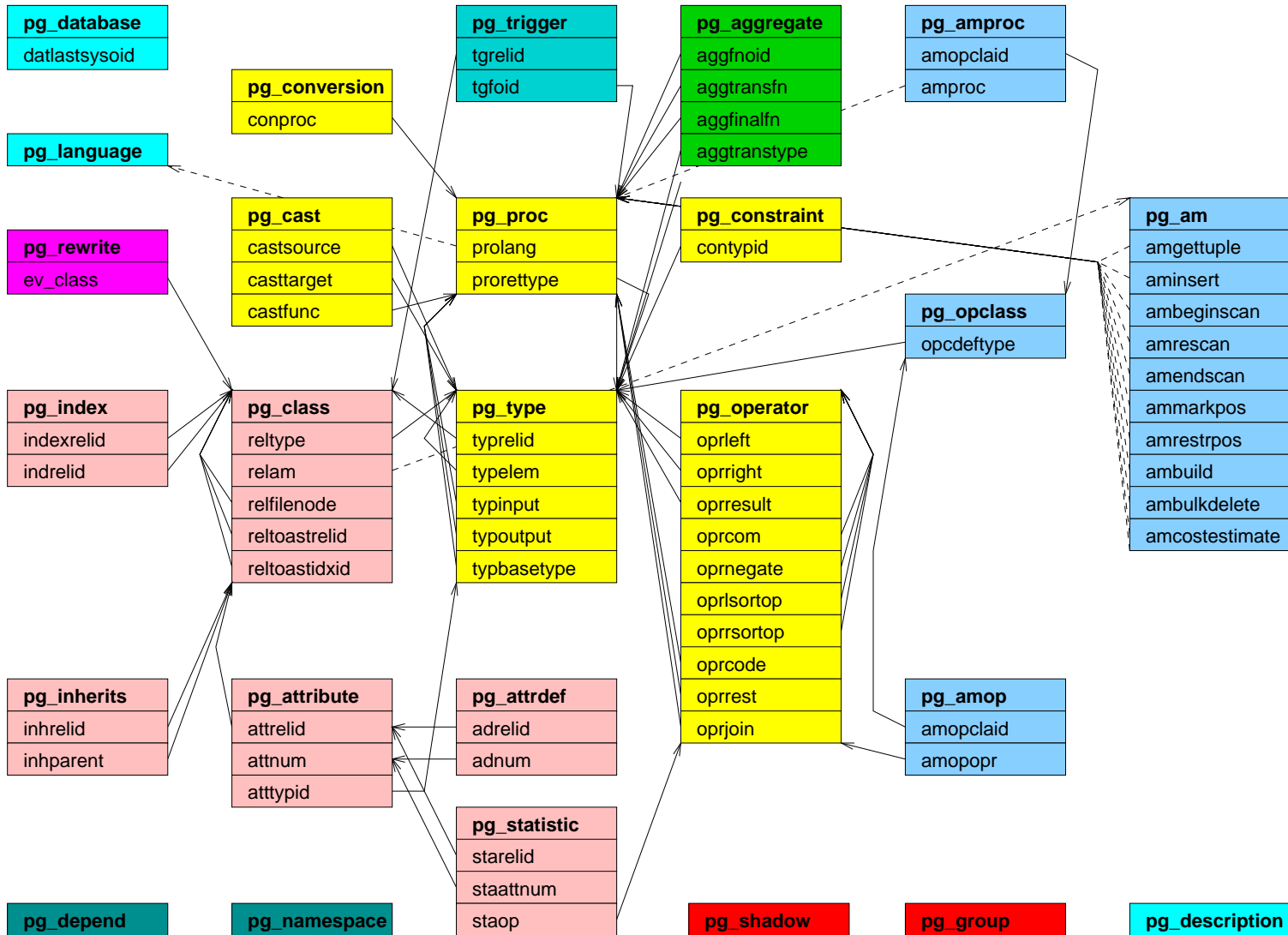

CONCLUSION

